

Mixing Unit

Fully automatic machine, mixing capacity to 40 m³/h
Separate reservoir is recommended depending on the application



RG-Anlagenbau Typ: CMA 1000

Mixing vessel useful capacity:	1500 l
Water storage tank:	2400 l
Output connection:	Perrot 4" VT
Drive power mixer:	25 kw / 400V
Possible 3 cement screw:	je 7,5 kw / 400V

Separate storage tank, maximum amount,
control over Ultrasonic.

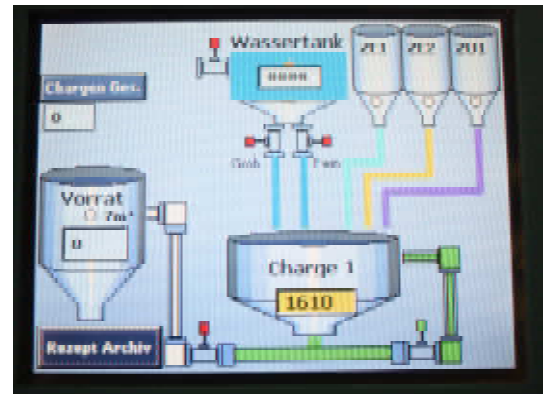

Seitenansicht

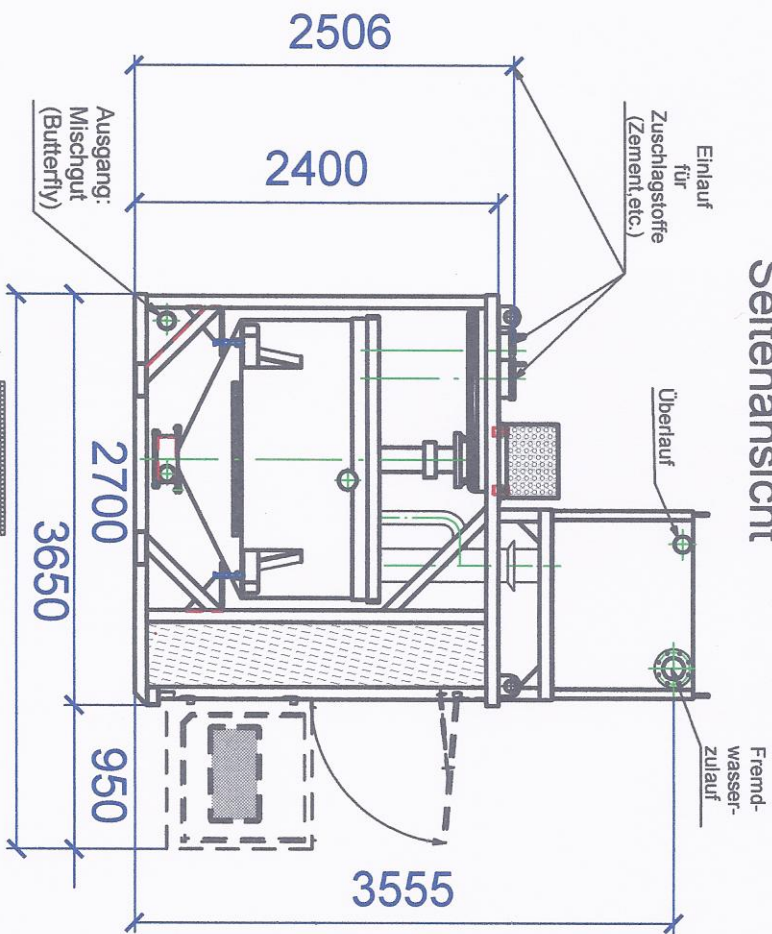

Ansicht: Schaltschrank-Seite

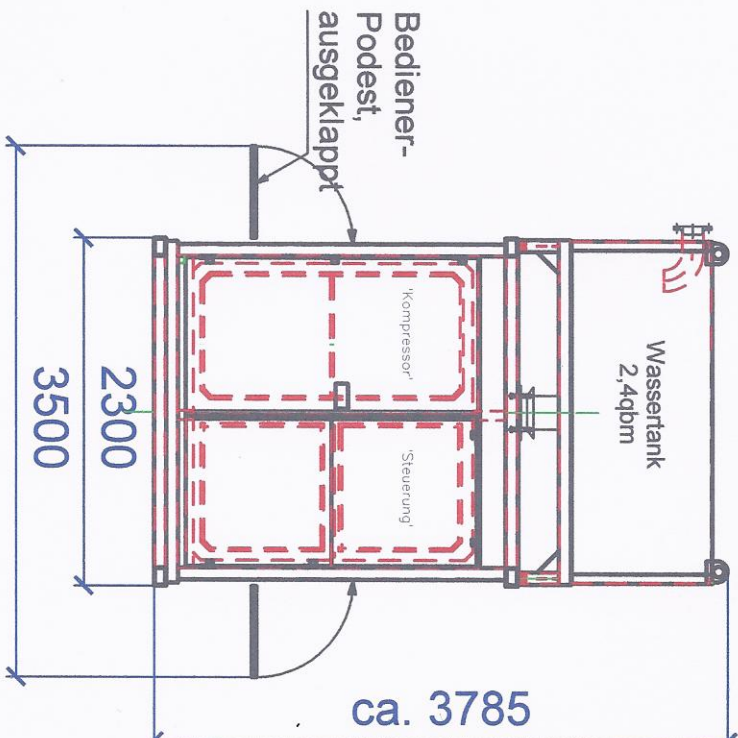

Draufsicht

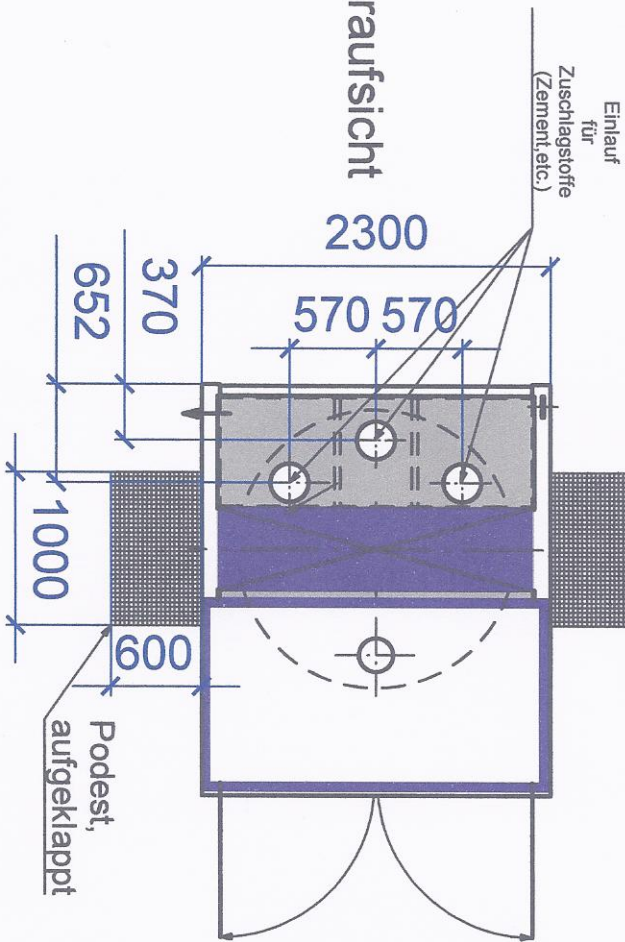

Entwurf :		Benennung :		Version	
bearb. : Kubbe		RG-Anlagenbau		Reinmund Gause	
geprüft :		Hauptstraße 17 A		29356 Bröckel	
Maßstab		Tel: 0152-08863668		Fax: 05144-972730	
1 : 50		Chargen-Mischer		für stationären Betrieb -	
		-Abmaße		Blatt	
		Zerchnng.-Nr.:		Bl.	
		130513-000.0			

Ansicht
Schaltschrank-
Seite

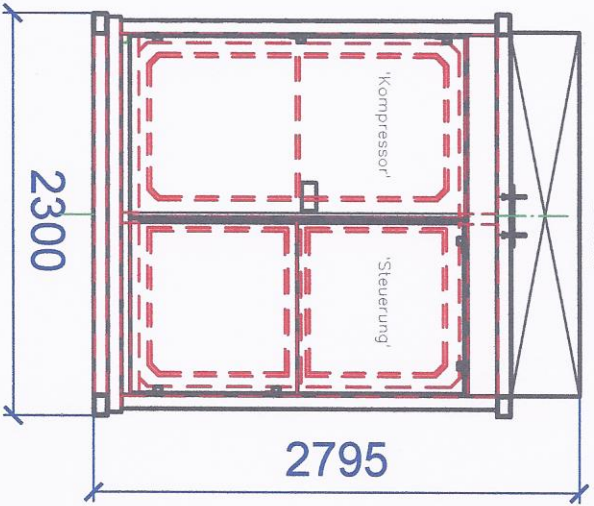

Seitenansicht
ohne Wassertank

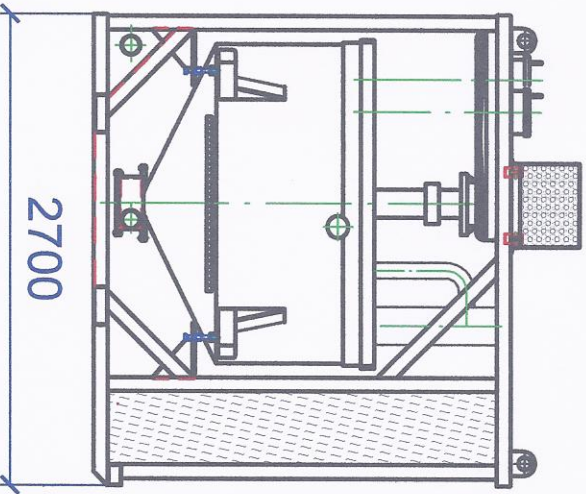

Chargen-Mischer

Gewicht,
ohne
Wassertank
ca. 3000 kg

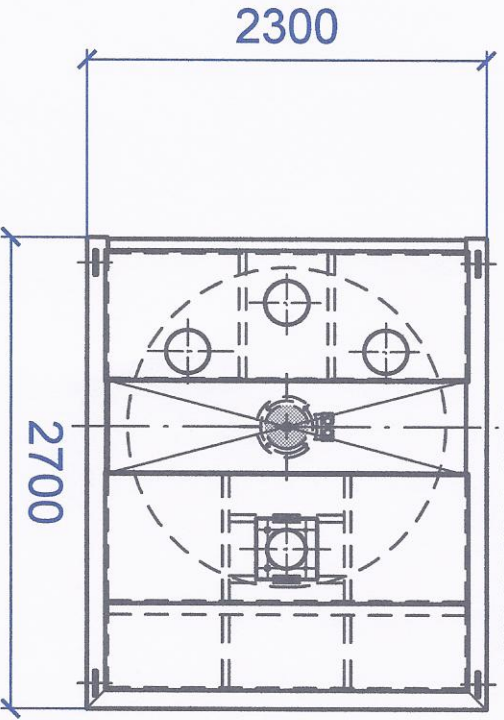

Draufsich Dach,
ohne Wassertank

Wassertank
Gewicht, leer
ca. 400 kg

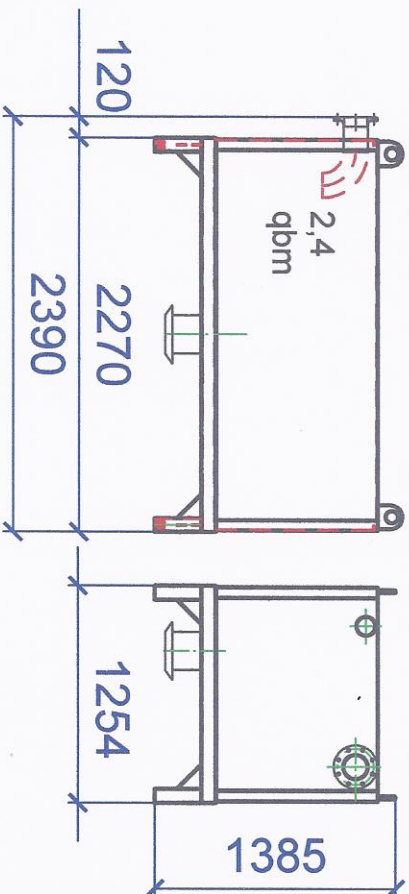

Entwurf :		Benennung : RG-Anlagenbau Reimund Gause Hauptstraße 17 A 29356 Bröckel Tel: 0152-08863668 Fax: 05144-972730	Version
bearb. :			
geprüft :			
Maßstab		Zeichng.-Nr.: 130513-000.0	Blatt
1:50			Bl.

**Chargen-Mischer
-Abmaße Transport -**