



# LT VALVE TECHNICAL MANUAL



**MSI is a division of Dixie Iron Works, Ltd.**

300 West Main St.  
Alice, Texas 78332  
Phone: 1-800-242-0059  
Phone: 1-361-664-6597  
Fax: 1-361-664-4840  
Email: [sales@diwmsi.com](mailto:sales@diwmsi.com)

**TABLE OF CONTENTS**

<b>1.0 FEATURES</b> .....	3
<b>1.1 SAFE-TAP™ GREASE FITTING</b> .....	4
<b>1.2 GREASEAL™ PLUG</b> .....	5
<b>2.0 EXPLODED VIEW</b> .....	6
<b>2.1 PARTS LIST</b> .....	7
<b>3.0 ASSEMBLY PROCEDURE – UNISERT™ TYPE</b> .....	8
<b>3.1 ASSEMBLY PROCEDURE – UNISERT™ TYPE (TEXT)</b> .....	19
<b>3.2 ASSEMBLY PROCEDURE – SPLIT INSERT TYPE</b> .....	21
<b>3.3 ASSEMBLY PROCEDURE – SPLIT INSERT TYPE (TEXT)</b> .....	31
<b>4.0 EXPLODED VIEW (5 INCH )</b> .....	33
<b>4.1 PARTS LIST</b> .....	34
<b>5.0 ASSEMBLY PROCEDURE – UNISERT™ TYPE (5 INCH)</b> .....	35
<b>5.1 ASSEMBLY PROCEDURE – UNISERT™ TYPE (5 INCH)</b> <b>(TEXT)</b> .....	44
<b>5.2 ASSEMBLY PROCEDURE –SPLIT INSERT TYPE (5 INCH)</b> ...	46
<b>5.3 ASSEMBLY PROCEDURE –SPLIT INSERT TYPE (5 INCH)</b> <b>(TEXT)</b> .....	55
<b>6.0 DISASSEMBLY PROCEDURE</b> .....	57
<b>7.0 MAINTENANCE</b> .....	58
<b>8.0 REPAIR AND INSPECTION</b> .....	59
<b>8.1 DISASSEMBLY TIPS</b> .....	61
<b>8.2 SANDING TIPS</b> .....	62
<b>8.3 ASSEMBLY TIPS</b> .....	63
<b>9.0 STORAGE</b> .....	64
<b>9.1 SHELF LIFE</b> .....	65
<b>10.0 ACCESSORIES</b> .....	66
<b>10.1 GREASES</b> .....	67
<b>10.2 GREASE REQUIREMENTS</b> .....	68
<b>10.3 ACTUATORS</b> .....	69
<b>10.4 RUBBER PRODUCTS</b> .....	70

## 1.0 FEATURES

The MSI LT Plug Valve is a lubricated, tapered pocket, quarter-turn plug valve for rapid full open or close operation. The valve cavity is tapered to ensure uniform seating of the sealing inserts, providing a reliable seal at the full range of pressures. The MSI LT Plug Valve and replacement parts are engineered to provide low operating torque and resistance to the toughest abrasive and corrosive conditions.

MSI offers more end connection choices than any other plug valve manufacturer in the industry. Connection types such as Hammer Unions, Line Pipe, API Flanged, Tool Joint, Clamp Hub, and our own metal-to-metal WingSeal (WS20 and WS30) are just a few of the available choices. All sizes of MSI valves can be outfitted with your choice of end connections or combinations to suit your specific application. Custom end-to-end lengths are also available on some valves.

- Compact Design
- Lightweight
- Longer lasting internals
- Ease of repair
- Interchangeability
- SafeTap™ grease fitting
- UNIsert™ integral insert
- **GreaSeal™** plug for full 360° greasing
- Widest range of end connections in the industry
  - Hammer union (all sizes of 602, 1002, 1502, 2002, 2202)
  - API Flange & Studded (all sizes and working pressures)
  - **WingSeal 20 (2.00"ID) & 30 (3.00"ID)** \*metal-to-metal
  - Clamp Hub (all sizes such as B20, GR14, GR31, plus API clamp hubs)
  - Threaded Ends (all sizes of Line Pipe, EU, NU, and premium threads)
  - Tool Joint (All sizes of IF and ACME unions)

## 1.1 SAFETAP™ GREASE FITTING

**SafeTap™** grease fittings are designed to provide maximum safe operation in the field. These fittings are standard in all new LT valves. Key features include:

- The unique metal-to-metal seal eliminates wetted threads and pipe taps. Since the threads do not perform a sealing function they do not require Teflon tape or other sealing aids.
- The heavier cross section stands up better to impacts.
- Each fitting has a slot machined through the threads which serves as a pressure relief path in the event of a leak.
- The metal-to-metal seal and the pressure relief slot of the **SafeTap™** grease fitting also allow a means to safely bleed any residual internal pressure.

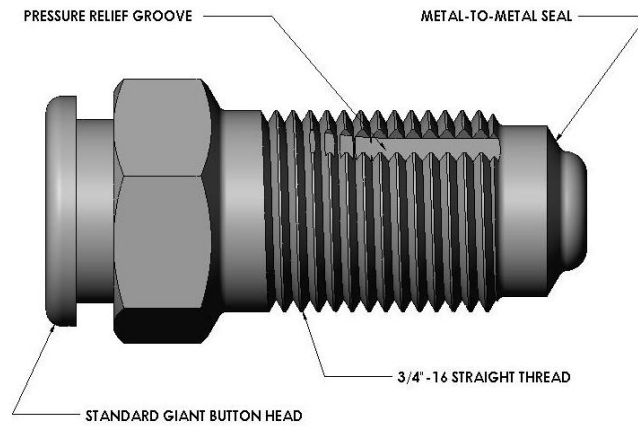

## 1.2 GREASEAL™ PLUG

The patented GreaSeal™ plug is designed to provide maximum lubrication in the harshest field conditions. Key features include:

- The only plug that allows greasing in the opened or closed position while in service.
- Dual 360° grease channels.
- Forces grease into 360° of the seal area when closed.
- Allows for complete distribution of lubricant immediately prior to opening a valve when exposure to high temperatures and well fluids may have compromised the existing grease.
- Greasing in the closed position can stop or significantly slow leaks in valves with worn or damaged parts.
- Grease fitting installs from the bottom of the plug for added protection from impacts.

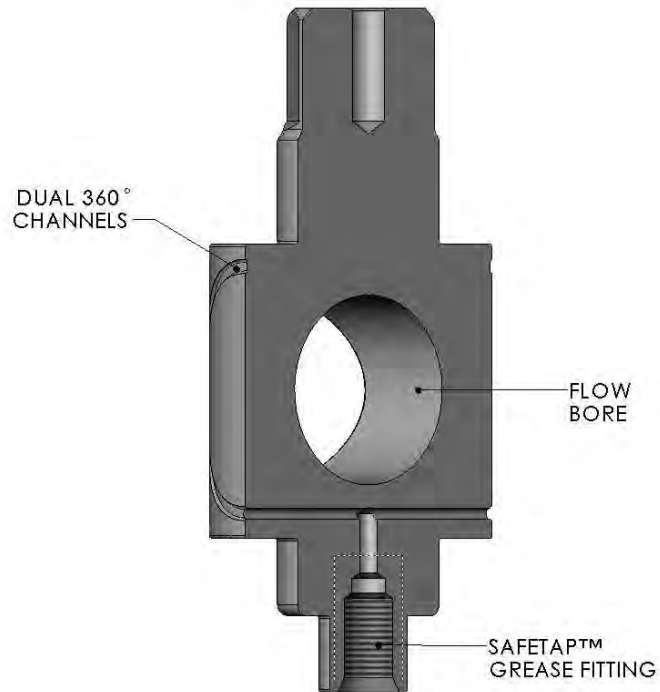

**2.0 EXPLODED VIEW**

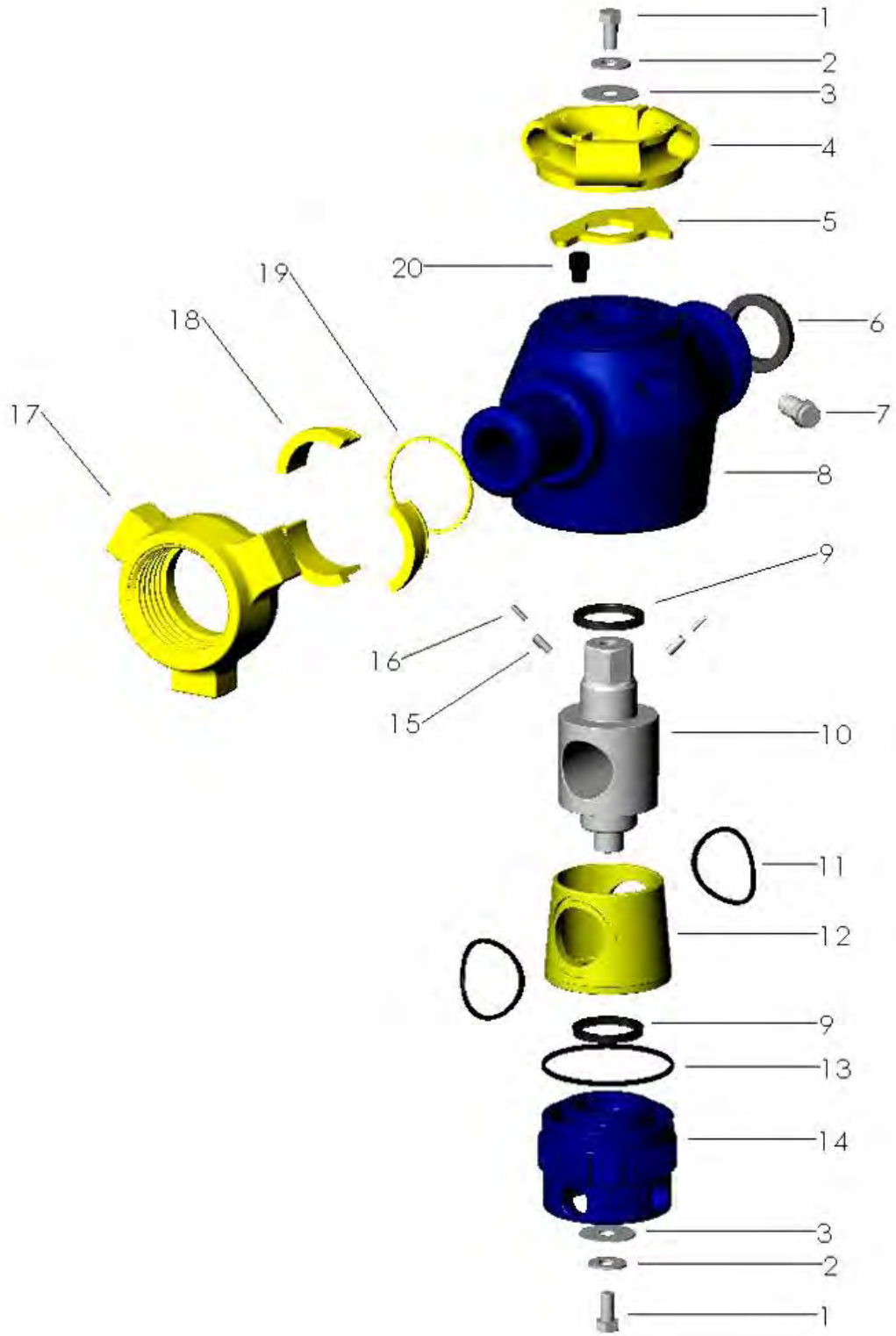

**2.1 PARTS LIST**

<b>NO.</b>	<b>QTY REQ'D</b>	<b>DESCRIPTION</b>
<b>1</b>	<b>2</b>	<b>PLUG BOLT</b>
<b>2</b>	<b>2</b>	<b>WASHER (SMALL)</b>
<b>3</b>	<b>2</b>	<b>WASHER (LARGE)</b>
<b>4</b>	<b>1</b>	<b>HANDLE ADAPTER</b>
<b>5</b>	<b>1</b>	<b>STOP COLLAR</b>
<b>6</b>	<b>1</b>	<b>RESILIENT SEAL</b>
<b>7</b>	<b>1</b>	<b>SAFETAP™ GREASE FITTING</b>
<b>8</b>	<b>1</b>	<b>VALVE BODY</b>
<b>9</b>	<b>2</b>	<b>PLUG SEAL</b>
<b>10a</b>	<b>1</b>	<b>PLUG</b>
<b>10b</b>	<b>1</b>	<b>GreaSeal™ PLUG</b>
<b>11</b>	<b>2</b>	<b>INSERT O-RING</b>
<b>12a</b>	<b>1</b>	<b>UNIsert™</b>
<b>12b</b>	<b>1</b>	<b>INSERT SET (SPLIT)</b>
<b>13</b>	<b>1</b>	<b>ADJUSTING NUT O-RING</b>
<b>14</b>	<b>1</b>	<b>ADJUSTING NUT</b>
<b>15</b>	<b>2</b>	<b>ROLL PIN (OUTER) (LG)</b>
<b>16</b>	<b>2</b>	<b>ROLL PIN (INNER) (SM)</b>
<b>17</b>	<b>1</b>	<b>WING NUT</b>
<b>18</b>	<b>1</b>	<b>NUT RETAINER SET</b>
<b>19</b>	<b>1</b>	<b>SPIRAL RETAINER RING</b>
<b>20</b>	<b>1</b>	<b>STOP BOLT</b>



### 3.0 ASSEMBLY PROCEDURE – UNISERT™ TYPE

**NOTE: It is imperative that the workstation being used to assemble the valve be clean and free of anything that could possibly contaminate the grease such as metal shavings, dirt, rust, old paint, etc. Do not sand or deburr near the workstation.**

- Check surfaces around the valve bore inside the valve pocket for sharp edges that could cause cutting of the insert o-rings. Then screw the clean **adjusting nut (14)** all the way into the valve body to make sure the threads are not damaged.



- After inspection, remove the **adjusting nut (14)**, grease the sealing groove and install the adjusting nut **o ring (13)** in the groove.



- Check the **roll pins (15 & 16)** in the valve body by gently sliding a **UNIsert™ (12)** into the valve. The **UNIsert™ (12)** should move freely up and down the length of the roll pin slots without interference.





- Apply a thin film of lubricant to the recess in the **valve body (8)** and install the **plug seal (9)** with the metal back towards the recess facing away from the pressure.

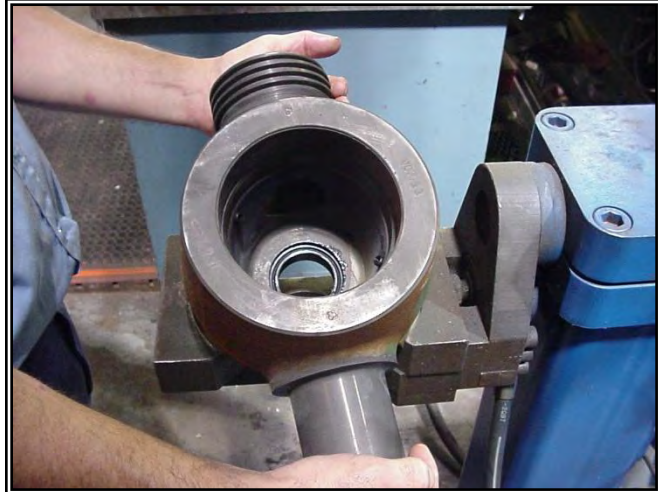

- Apply a thin film of lubricant to the recess in the **adjusting nut (14)** and install the **plug seal (9)** with the metal back towards the recess facing away from the pressure.



- Check the **plug (10)** outside diameter for surface defects such as scratches, dings, nicks, or sharp edges that could affect the sealing area. See [8.2 SANDING TIPS](#) for repair.



- Check the surface finish of the **UNInsert™ (12)** making sure it does not have any scratches, dings, nicks or sharp edges that could also affect the sealing area. See **8.2 SANDING TIPS** for repair.



- Inspect the **adjusting nut o-ring (13)** for any possible non-conformity.



- Pack the **adjusting nut (14) plug seal (9)** with valve grease.





- Place the **UNIsert™ (12)** on the **adjusting nut (14)**.



- Apply a thin film of grease to the entire O.D. of the **plug (10)**.



- Install the lower end of the **plug (10)** (opposite the hex) in the **UNIsert™ (12)** and **adjusting nut (14)** and push down until the plug shoulders on the adjusting nut.



- Place the **insert o-rings (11)** in to the grooves on the **UNIsert™ (12)** and pack with grease to retain the rings and thoroughly grease the sealing surfaces.



- Secure the **plug (10)** to the **adjusting nut (14)** with the **plug bolt (1)** and two **washers (2 & 3)**.



- Lubricate the valve pocket with valve grease.



- Apply thread compound (Never-Seez) to the adjusting nut threads and adjusting nut sealing surfaces.



- Support the valve so that the **plug (10)** hex can pass through unobstructed.



- Install the **plug (10)**, **UNInsert™ (12)** and **adjusting nut (14)** assembly into the valve body.





- Screw in the adjusting nut until proper alignment is obtained between the valve bore, the **UNInsert™** and plug. Do not tighten beyond proper alignment as actuating an over tightened valve could damage internal parts. If sight through the bore is not possible, then screw in the adjusting nut until  $\frac{1}{2}$  or no thread is visible.



- Apply thread compound (never Seez) to the threads on the **SafeTap™ grease fitting (7)**.

**NOTE: Do not use Teflon tape on the grease fitting.**



- Install **SafeTap™ grease fitting (7)** and torque to 80 ft-lbs.



- Place **spiral retainer ring (19)** on male end (if required).



- Then place **wing nut (17)** on male end and install the **nut retainer set (18)** (if required).



- Secure the retainers with spiral retainer ring (if required)





- Install **stop bolt (20)**.



- Install **stop collar (5)**.

**NOTE: Valves with bores smaller than 2" do not use a stop collar, the detent is integral to the handle adapter.**



- Install the **handle adapter (4)**.



- Secure **handle adapter (4)** with the **plug bolt (1)** and **washers (2 & 3)**.



- Remove excess grease from valve bore.



- Inspect plug alignment and adjust as necessary with **adjusting nut (14)**.

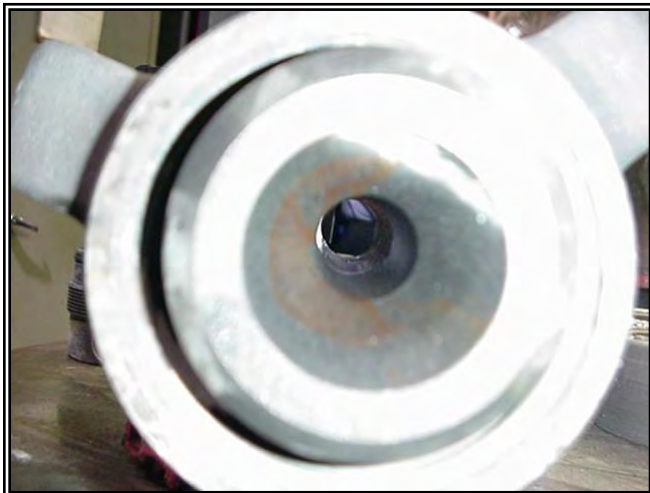

- o Grease the counter bore of the valve body female end and press the **resilient seal (19)** lip end towards the valve in until the lip on the OD of the seal snaps into the groove in the back of the counter bore.



### 3.1 ASSEMBLY PROCEDURE – UNISERT™ TYPE (TEXT)

**NOTE: It is imperative that the workstation being used to assemble the valve be clean and free of anything that could possibly contaminate the grease such as metal shavings, dirt, rust, old paint, etc. Do not sand or deburr near the workstation.**

1. Check surfaces around the valve bore inside the valve pocket for sharp edges that could cause cutting of the insert o-rings. Then screw the clean **adjusting nut (14)** all the way into the valve body to make sure the threads are not damaged.
2. After inspection, remove the **adjusting nut (14)**, grease the sealing groove and install the adjusting nut **o ring (13)** in the groove.
3. Check the **roll pins (15 & 16)** in the valve body by gently sliding a **UNIsert™ (12)** into the valve. The **UNIsert™ (12)** should move freely up and down the length of the roll pin slots without interference.
4. Apply a thin film of lubricant to the recess in the **valve body (8)** and install the **plug seal (9)** with the metal back towards the recess facing away from the pressure.
5. Apply a thin film of lubricant to the recess in the **adjusting nut (14)** and install the **plug seal (9)** with the metal back towards the recess facing away from the pressure.
6. Check the **plug (10)** outside diameter for surface defects such as scratches, dings, nicks, or sharp edges that could affect the sealing area. See [8.2 SANDING TIPS](#) for repair.
7. Check the surface finish of the **UNIsert™ (12)** making sure it does not have any scratches, dings, nicks or sharp edges that could also affect the sealing area. See [8.2 SANDING TIPS](#) for repair.
8. Inspect the **adjusting nut o-ring (13)** for any possible non-conformity.
9. Pack the **adjusting nut (14) plug seal (9)** with valve grease.
10. Place the **UNIsert™ (12)** on the **adjusting nut (14)**.
11. Apply a thin film of grease to the entire O.D. of the **plug (10)**.
12. Install the lower end of the **plug (10)** (opposite the hex/keyway) in the **UNIsert™ (12)** and **adjusting nut (14)** and push down until the plug shoulders on the adjusting nut.
13. Place the **insert o-rings (11)** in to the grooves on the **UNIsert™ (12)** and pack with grease to thoroughly grease the sealing surfaces.
14. Secure the **plug (10)** to the **adjusting nut (14)** with the **plug bolt (1)** and two **washers (2 & 3)**.

15. Lubricate the valve pocket with valve grease.
16. Apply thread compound (Never-Seez) to the adjusting nut threads and adjusting nut sealing surfaces.
17. Support the valve so that the **plug (10)** hex can pass through unobstructed.
18. Install the **plug (10)**, **UNIsert™ (12)** and **adjusting nut (14)** assembly into the valve body.
19. Screw in the adjusting nut until proper alignment is obtained between the valve bore, the **UNIsert™** and plug. Do not tighten beyond proper alignment as actuating an over tightened valve could damage internal parts. If sight through the bore is not possible, then screw in the adjusting nut until ½ or no thread is visible.
20. Apply thread compound (Never-Seez) to the threads on the SafeTap™ **grease fitting (7)**. **NOTE: Do not use Teflon tape on the grease fitting.**
21. Install **SafeTap™ grease fitting (7)** and torque to 80 ft-lbs.
22. Place **spiral retainer ring (19)** on male end (if required).
23. Then place **wing nut (17)** on male end and install the **nut retainer set (18)** (if required).
24. Secure the retainers with spiral retainer ring (if required).
25. Install **stop bolt (20)**.
26. Install **stop collar (5)**. **NOTE: Valves with bores smaller than 2" do not use a stop collar, the detent is integral to the handle adapter.**
27. Install the **handle adapter (4)**.
28. Secure **handle adapter (4)** with the **plug bolt (1)** and **washers (2 & 3)**.
29. Remove excess grease from valve bore.
30. Inspect plug alignment and adjust as necessary with **adjusting nut (14)**.
31. Grease the counter bore of the valve body female end and press the **resilient seal (19)** lip end towards the valve in until the lip on the OD of the seal snaps into the groove in the back of the counter bore.



### 3.2 ASSEMBLY PROCEDURE – SPLIT INSERT TYPE

**NOTE: It is imperative that the workstation being used to assemble the valve be clean and free of anything that could possibly contaminate the grease such as metal shavings, dirt, rust, old paint, etc. Do not sand or deburr near the workstation.**

- Check surfaces around the valve bore inside the valve pocket for sharp edges that could cause cutting of the insert o-rings. Then screw the clean **adjusting nut (14)** all the way into the valve body to make sure the threads are not damaged.



- After inspection, remove the **adjusting nut (14)**, grease the sealing groove and install the adjusting nut **o ring (13)** in the groove.



- Check the **roll pins (15 & 16)** in the valve body by gently sliding a set of **inserts (12)** into the valve. The **inserts (12)** should move freely up and down the length of the roll pin slots without interference.



- Apply a thin film of lubricant to the recess in the **valve body (8)** and install the **plug seal (9)** with the metal back towards the recess facing away from the pressure.



- Apply a thin film of lubricant to the recess in the **adjusting nut (14)** and install the **plug seal (9)** with the metal back towards the recess facing away from the pressure.



- Check the **plug (10)** outside diameter for surface defects such as scratches, dings, nicks, or sharp edges that could affect the sealing area. See [8.2 SANDING TIPS](#) for repair.





- Apply grease to the **plug seal (9)** in the **adjusting nut (14)**.



- Install the lower end of the **plug (10)** (opposite the hex) in the **adjusting nut (14)** and push down until the plug shoulders on the adjusting nut.

**NOTE: For the 0.38" and 1" valves, do not push the plug (10) all the way down yet.**



- Apply a thin film of grease to the entire O.D. of the **plug (10)**.



- Check the surface finish of the **inserts (12)** making sure they do not have any scratches, dings, nicks or sharp edges that could affect the sealing area. See **8.2 SANDING TIPS** for repair.



- Inspect the **insert o-rings (11)** for any possible non-conformity.



- Place the **inserts (12)** around the **plug (10)**.

**NOTE: For the 0.38" and 1" valves, push the plug (10) all the way down now.**



- Install the **insert o-rings (11)** into the **insert (12)** grooves and coat with grease to retain the rings.



- Make sure the entire sealing surface is thoroughly greased.



- Secure the plug to the adjusting nut with the **plug bolt (1)** and **washers (2 & 3)**.





- Lubricate the valve pocket with valve grease.



- Apply thread compound (Never-Seez) to the adjusting nut threads and adjusting nut sealing surfaces.



- Install the **plug (10)**, **inserts (12)** and **adjusting nut (14)** assembly into the valve body.



- Support the valve so that the **plug (10)** hex can pass through unobstructed.



- Tighten the **adjusting nut (14)** until snug and back off ¼ turn from snug position.



- Apply thread compound (Never Seez) to the threads on the **SafeTap™ grease fitting (7)**. Install grease fitting and torque to 80 ft-lbs.

**NOTE: Do not use Teflon tape on the grease fitting.**





- Place **spiral retainer ring (19)** on male end (if required).



- Then place **wing nut (17)** on male end and install the **nut retainer set (18)** (if required).



- Secure the retainers with spiral retainer ring (if required)



- Install **stop bolt (20)**.



- Install **stop collar (5)** and **handle adapter (4)**.

**NOTE: Valves with bores smaller than 2" do not use a stop collar, the detent is integral to the handle adapter.**



- Secure **handle adapter (4)** with the **plug bolt (1)** and **washers (2 & 3)**.





- Remove excess grease from valve bore.



- Inspect plug alignment and adjust as necessary with **adjusting nut (14)**.

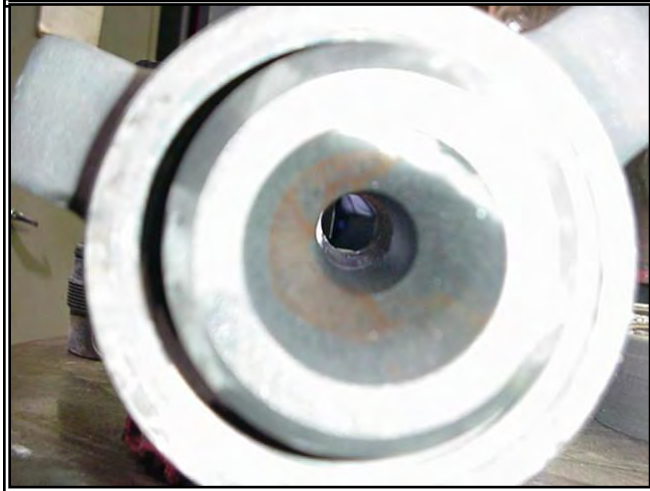

- Grease the counter bore of the valve body female end and press the **resilient seal (19)** in until the lip on the OD of the seal snaps into the groove in the back of the counter bore.



### 3.3 ASSEMBLY PROCEDURE – SPLIT INSERT TYPE (TEXT)

**NOTE: It is imperative that the workstation being used to assemble the valve be clean and free of anything that could possibly contaminate the grease such as metal shavings, dirt, rust, old paint, etc. Do not sand or deburr near the workstation.**

1. Check surfaces around the valve bore inside the valve pocket for sharp edges that could cause cutting of the insert o-rings. Then screw the clean **adjusting nut (14)** all the way into the valve body to make sure the threads are not damaged.
2. After inspection, remove the **adjusting nut (14)**, grease the sealing groove and install the adjusting nut **o ring (13)** in the groove.
3. Check the **roll pins (15 & 16)** in the valve body by gently sliding a set of **insert (12)** into the valve. The **inserts (12)** should move freely up and down the length of the roll pin slots without interference.
4. Apply a thin film of lubricant to the recess in the **valve body (8)** and install the **plug seal (9)** with the metal back towards the recess facing away from the pressure.
5. Apply a thin film of lubricant to the recess in the **adjusting nut (14)** and install the **plug seal (9)** with the metal back towards the recess facing away from the pressure.
6. Check the **plug (10)** outside diameter for surface defects such as scratches, dings, nicks, or sharp edges that could affect the sealing area. See [8.2 SANDING TIPS](#) for repair.
7. Apply grease to the **plug seal (9)** in the **adjusting nut (14)**.
8. Install the lower end of the **plug (10)** (opposite the hex/keyway) in the **adjusting nut (14)** and push down until the plug shoulders on the adjusting nut. **NOTE: For the 0.38" and 1" valves, do not push the plug (10) all the way down yet.**
9. Apply a thin film of grease to the entire O.D. of the **plug (10)**.
10. Check the surface finish of the **inserts (12)** making sure they do not have any scratches, dings, nicks or sharp edges that could affect the sealing area. See [8.2 SANDING TIPS](#) for repair.
11. Inspect the **insert o-rings (11)** for any possible non-conformity.
12. Place the **inserts (12)** around the **plug (10)**. **NOTE: For the 0.38" and 1" valves, push the plug (10) all the way down now.**
13. Install the **insert o-rings (11)** into the **insert (12)** grooves and coat with grease.

14. Make sure the entire sealing surface is thoroughly greased.
15. Secure the plug to the adjusting nut with the **plug bolt (1)** and **washers (2 & 3)**.
16. Lubricate the valve pocket with valve grease.
17. Apply thread compound (Never-Seez) to the adjusting nut threads and adjusting nut sealing surfaces.
18. Install the **plug (10)**, **inserts (12)** and **adjusting nut (14)** assembly into the valve body.
19. Support the valve so that the **plug (10)** hex can pass through unobstructed.
20. Tighten the **adjusting nut (14)** until snug and back off ¼ turn from snug position.
21. Apply thread compound (Never Seez) to the threads on the SafeTap™ **grease fitting (7)**. Install grease fitting and torque to 80 ft-lbs. **NOTE: Do not use Teflon tape on the grease fitting.**
22. Place **spiral retainer ring (19)** on male end (if required).
23. Then place **wing nut (17)** on male end and install the **nut retainer set (18)** (if required).
24. Secure the retainers with spiral retainer ring (if required)
25. Install **stop bolt (20)**.
26. Install **stop collar (5)** and **handle adapter (4)**. **NOTE: Valves with bores smaller than 2" do not use a stop collar, the detent is integral to the handle adapter.**
27. Secure **handle adapter (4)** with the **plug bolt (1)** and **washers (2 & 3)**.
28. Remove excess grease from valve bore.
29. Inspect plug alignment and adjust as necessary with **adjusting nut (14)**.
30. Grease the counter bore of the valve body female end and press the **resilient seal (19)** in until the lip on the OD of the seal snaps into the groove in the back of the counter bore.

### 4.0 EXPLODED VIEW (5" VALVE)

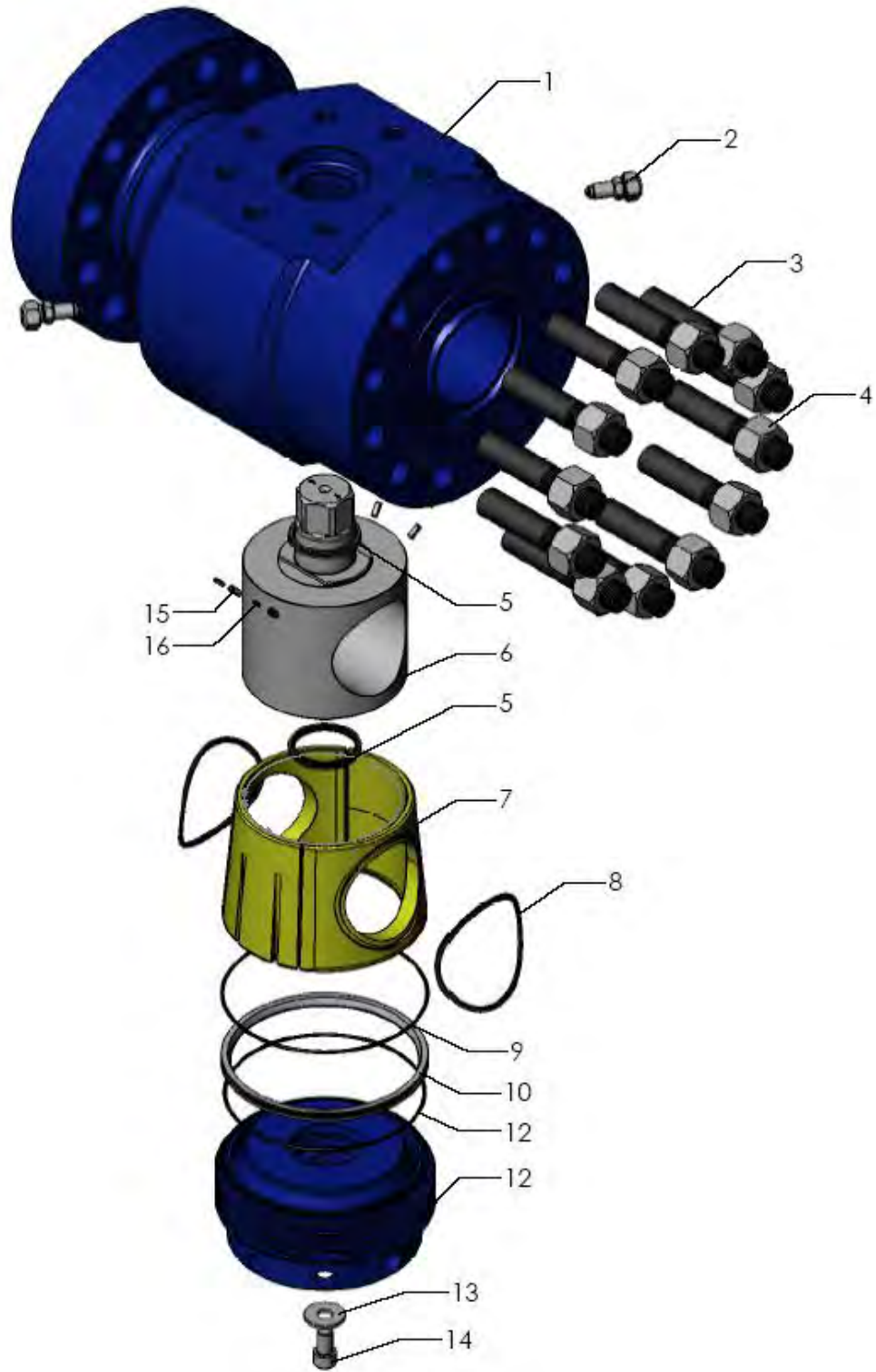

**4.1 PARTS LIST (5" VALVE)**

<b>NO.</b>	<b>QTY REQ'D</b>	<b>DESCRIPTION</b>
<b>1</b>	<b>1</b>	<b>VALVE BODY</b>
<b>2</b>	<b>2</b>	<b>SAFETAP™ GREASE FITTING</b>
<b>3</b>	<b>12</b>	<b>STUDS</b>
<b>4</b>	<b>12</b>	<b>NUTS</b>
<b>5</b>	<b>2</b>	<b>PLUG SEAL</b>
<b>6a</b>	<b>1</b>	<b>PLUG</b>
<b>6b</b>	<b>1</b>	<b>GreaSeal™ PLUG</b>
<b>7a</b>	<b>1</b>	<b>UNIsert™</b>
<b>7b</b>	<b>1</b>	<b>INSERT SET (SPLIT)</b>
<b>8</b>	<b>2</b>	<b>INSERT O-RING</b>
<b>9</b>	<b>1</b>	<b>O RING, FACE SEAL RING</b>
<b>10</b>	<b>1</b>	<b>SEAL RING</b>
<b>11</b>	<b>1</b>	<b>O RING, ADJUSTING NUT</b>
<b>12</b>	<b>1</b>	<b>ADJUSTING NUT</b>
<b>13</b>	<b>1</b>	<b>FLAT WASHER</b>
<b>14</b>	<b>1</b>	<b>SOCKET HEAD BOLT</b>
<b>15</b>	<b>4</b>	<b>ROLL PIN (OUTER) (LG)</b>
<b>16</b>	<b>4</b>	<b>ROLL PIN (INNER) (SM)</b>



## 5.0 ASSEMBLY PROCEDURE – UNISERT™ TYPE (5" VALVE)

**NOTE:** It is imperative that the workstation being used to assemble the valve be clean and free of anything that could possibly contaminate the grease such as metal shavings, dirt, rust, old paint, etc. Do not sand or deburr near the workstation.

**All assembly steps must be done with the valve pocket in the vertical position. Any attempt to screw the adjusting nut in with the valve pocket in the horizontal position could result in damage to the adjusting nut and valve sealing components.**

- Check surfaces around the valve bore inside the valve pocket for sharp edges that could cause cutting of the insert o-rings. Then screw the clean **adjusting nut (12)** all the way into the valve body to make sure the threads are not damaged.



- After inspection remove the adjusting nut and check the **roll pins (15 & 16)** in the valve body by gently sliding the **insert (7)** into the valve. The **insert (7)** should move freely up and down the length of the roll pin slots without interference.



- Apply a thin film of lubricant to the recess in the **adjusting nut (12)** and install the **plug seal (5)** with the metal back towards the recess facing away from the pressure.



- Apply grease to the **plug seal (5)** in the **adjusting nut (12)**.



- Grease the sealing groove and install the adjusting nut **o ring (11)** in the groove.





- Apply a thin film of lubricant to the pocket and the recess in the **valve body (1)** and install the **plug seal (5)** with the metal back towards the recess facing away from the pressure.



- Check the **plug (6)** outside diameter for surface defects such as scratches, dings, nicks, or sharp edges that could affect the sealing area. See [8.2 SANDING TIPS](#) for repair.



- Support the valve so that the plug hex can pass through unobstructed.



- Install the **plug (6)** (hex side down) in the valve body.



- Check the surface finish of the **insert (7)** making sure they do not have any scratches, dings, nicks or sharp edges that could affect the sealing area. See [8.2 SANDING TIPS](#) for repair.



- Inspect the **insert o-rings (8)** for any possible non-conformity.



- Install the **insert o-rings (8)** into the **insert (7)** grooves and coat with grease to retain the rings.



- Make sure the entire sealing surface is thoroughly greased.



- Apply a thin film of grease to the entire I.D. of the **insert (7)**.





- Place the **insert (7)** around the **plug (6)** in the valve body making sure it slides into the roll pins.



- Apply thread compound (Never-Seez) to the adjusting nut threads and adjusting nut sealing surfaces.



- Grease the **seal ring (10)** groove and insert the **o ring (9)** over it.





- Place the **seal ring (10)** on the top of the **insert (7)**.



- Install the **adjusting nut (12)** into the valve body and tighten until snug and back off ¼ turn from the snug position.



- Apply thread compound (Never Seez) grease to the **plug bolt (14)** threads and tighten it with the allen wrench on the adjusting nut side of the **plug (6)**.



- Apply thread compound (Never Seez) to the threads **on the SafeTap™ grease fitting (2)**. Install grease fitting and torque to 80 ft-lbs.

**NOTE: Do not use Teflon tape on the grease fitting.**



- Remove excess grease from valve bore.



- Inspect plug alignment and adjust as necessary with **adjusting nut (12)**.



- Apply Removable Threadlocker (blue) in the threads of the stud end and screw the **studs (3)** until tight. Screw the **nuts (4)** on the **studs (3)**.

**Note: Do not use High Strength (red) Threadlocker.**





## 5.1 ASSEMBLY PROCEDURE- UNISERT™ TYPE (5" VALVE) (TEXT)

**NOTE: It is imperative that the workstation being used to assemble the valve be clean and free of anything that could possibly contaminate the grease such as metal shavings, dirt, rust, old paint, etc. Do not sand or deburr near the workstation.**

**All assembly steps must be done with the valve pocket in the vertical position. Any attempt to screw the adjusting nut in with the valve pocket in the horizontal position could result in damage to the adjusting nut and valve sealing components.**

1. Check surfaces around the valve bore inside the valve pocket for sharp edges that could cause cutting of the insert o-rings. Then screw the clean **adjusting nut (12)** all the way into the valve body to make sure the threads are not damaged.
2. After inspection remove the adjusting nut and check the **roll pins (15 & 16)** in the valve body by gently sliding the **insert (7)** into the valve. The **insert (7)** should move freely up and down the length of the roll pin slots without interference.
3. Apply a thin film of lubricant to the recess in the **adjusting nut (12)** and install the **plug seal (5)** with the metal back towards the recess facing away from the pressure.
4. Apply grease to the **plug seal (5)** in the **adjusting nut (12)**.
5. Grease the sealing groove and install the adjusting nut **o ring (11)** in the groove.
6. Apply a thin film of lubricant to the pocket and the recess in the **valve body (1)** and install the **plug seal (5)** with the metal back towards the recess facing away from the pressure.
- 7.
8. Check the **plug (6)** outside diameter for surface defects such as scratches, dings, nicks, or sharp edges that could affect the sealing area. [See 8.2 SANDING TIPS for repair.](#)
9. Support the **valve body (1)** so that the plug hex can pass through unobstructed.
10. Install the **plug (6)** (hex side down) in the **valve body (1)**.
11. Check the surface finish of the **inserts (7)** making sure they do not have any scratches, dings, nicks or sharp edges that could affect the sealing area. [See 8.2 SANDING TIPS for repair.](#)
12. Inspect the insert **o-rings (8)** for any possible non-conformity.
13. Install the insert **o-rings (8)** into the **insert (7)** grooves and coat with grease to retain the rings.

14. Make sure the entire sealing surface is thoroughly greased.
15. Apply a thin film of grease to the entire I.D. of the **insert (7)**.
16. Place the **insert (7)** around the **plug (6)** in the **valve body (1)** making sure it slides into the roll pins.
17. Apply thread compound (Never-Seez) to the adjusting nut threads and adjusting nut sealing surfaces.
18. Grease the **seal ring (10)** groove and insert the **o ring (9)** over it.
19. Place the **seal ring (10)** on the top of the **insert (7)**.
20. Install the **adjusting nut (12)** into the **valve body (1)** and tighten until snug and back off ¼ turn from the snug position.
21. Apply thread compound (Never Seez) grease to the **plug bolt (14)** threads and tighten it with the allen wrench on the adjusting nut side of the **plug (6)**.
22. Apply thread compound (Never Seez) to the threads on the **SafeTap™ grease fitting (2)**. Install grease fittings and torque to 80 ft-lbs.  
NOTE: Do not use Teflon tape on the grease fitting.
23. Remove excess grease from valve bore.
24. Inspect plug alignment and adjust as necessary with **adjusting nut (12)**.
25. Apply Removable Threadlocker (blue) in the threads of the stud end and screw the **studs (3)** until tight. Screw the **nuts (4)** over the **studs (3)**  
Note: Do not use Red High Strength Threadlocker.

## 5.2 ASSEMBLY PROCEDURE- SPLIT INSERT TYPE (5" VALVE)

**NOTE: It is imperative that the workstation being used to assemble the valve be clean and free of anything that could possibly contaminate the grease such as metal shavings, dirt, rust, old paint, etc. Do not sand or deburr near the workstation.**

**All assembly steps must be done with the valve pocket in the vertical position. Any attempt to screw the adjusting nut in with the valve pocket in the horizontal position could result in damage to the adjusting nut and valve sealing components.**

- Check surfaces around the valve bore inside the valve pocket for sharp edges that could cause cutting of the insert o-rings. Then screw the clean **adjusting nut (12)** all the way into the valve body to make sure the threads are not damaged.



- After inspection remove the adjusting nut and check the **roll pins (15 & 16)** in the valve body by gently sliding a set of **inserts (7)** into the valve. The **inserts (7)** should move freely up and down the length of the roll pin slots without interference.





- Apply a thin film of lubricant to the recess in the **adjusting nut (12)** and install the **plug seal (5)** with the metal back towards the recess facing away from the pressure.



- Apply grease to the **plug seal (5)** in the **adjusting nut (12)**.



- Grease the sealing groove and install the adjusting nut **o ring (11)** in the groove.



- Apply a thin film of lubricant to the pocket and the recess in the **valve body (1)** and install the **plug seal (5)** with the metal back towards the recess facing away from the pressure.



- Check the **plug (6)** outside diameter for surface defects such as scratches, dings, nicks, or sharp edges that could affect the sealing area. See [8.2 SANDING TIPS](#) for repair.



- Support the valve so that the plug hex can pass through unobstructed.



- Install the **plug (6)** (hex side down) in the valve body.



- Check the surface finish of the **inserts (7)** making sure they do not have any scratches, dings, nicks or sharp edges that could affect the sealing area. See [8.2 SANDING TIPS](#) for repair.

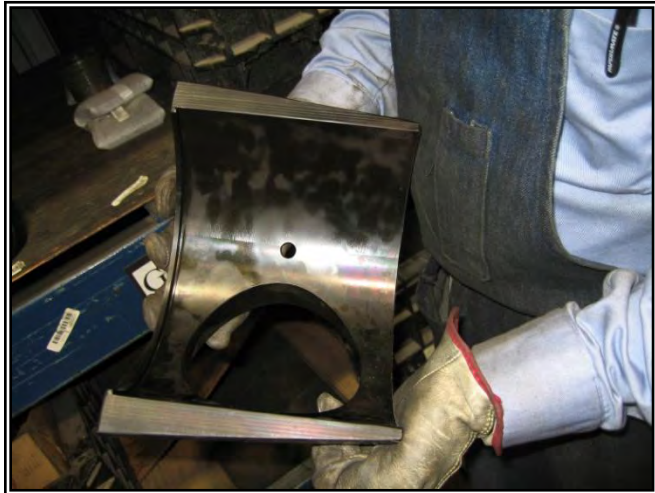

- Inspect the **insert o-rings (8)** for any possible non-conformity.





- Install the **insert o-rings (8)** into the **insert (7)** grooves and coat with grease to retain the rings.



- Make sure the entire sealing surface is thoroughly greased.

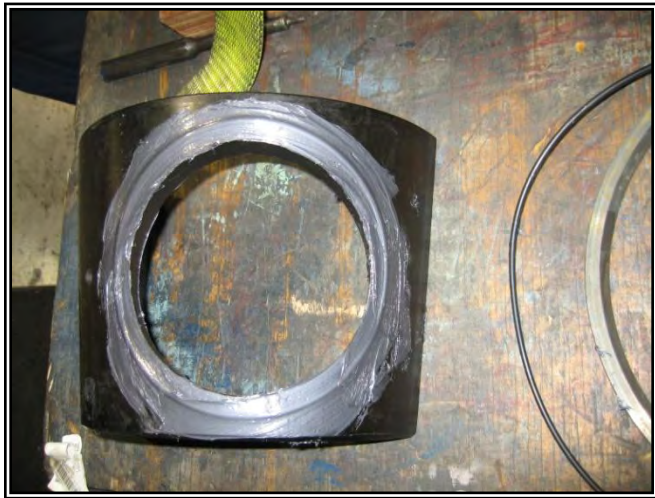

- Apply a thin film of grease to the entire I.D. of the **insert set (7)**.



- Place the **inserts (7)** around the **plug (6)** in the valve body making sure it slides into the roll pins.



- Apply thread compound (Never-Seez) to the adjusting nut threads and adjusting nut sealing surfaces.



- Grease the **seal ring (10)** groove and insert the **o ring (9)** over it.





- o Place the **seal ring (10)** on the top of the inserts.



- o Install the **adjusting nut (12)** into the valve body and tighten until snug and back off ¼ turn from the snug position.



- o Apply thread compound (Never Seez) grease to the **plug bolt (14)** threads and tighten it with the allen wrench on the adjusting nut side of the **plug (6)**.



- Apply thread compound (Never Seez) to the threads on the SafeTap™ **grease fitting (2)**. Install grease fitting and torque to 80 ft-lbs.

**NOTE: Do not use Teflon tape on the grease fitting.**



- Remove excess grease from valve bore.



- Inspect plug alignment and adjust as necessary with **adjusting nut (12)**.





- Apply Removable Threadlocker (blue) in the threads of the stud end and screw the **studs (3)** until tight. Screw the **nuts (4)** on the **studs (3)**.

**Note: Do not use Red High Strength Threadlocker.**



### 5.3 ASSEMBLY PROCEDURE- SPLIT INSERT (5" VALVE) (TEXT)

**NOTE: It is imperative that the workstation being used to assemble the valve be clean and free of anything that could possibly contaminate the grease such as metal shavings, dirt, rust, old paint, etc. Do not sand or deburr near the workstation.**

**All assembly steps must be done with the valve pocket in the vertical position. Any attempt to screw the adjusting nut in with the valve pocket in the horizontal position could result in damage to the adjusting nut and valve sealing components.**

1. Check surfaces around the valve bore inside the valve pocket for sharp edges that could cause cutting of the insert o-rings. Then screw the clean **adjusting nut (12)** all the way into the valve body to make sure the threads are not damaged.
2. After inspection remove the adjusting nut and check the **roll pins (15 & 16)** in the valve body by gently sliding a set of **inserts (7)** into the valve. The **inserts (7)** should move freely up and down the length of the roll pin slots without interference.
3. Apply a thin film of lubricant to the recess in the **adjusting nut (12)** and install the **plug seal (5)** with the metal back towards the recess facing away from the pressure.
4. Apply grease to the **plug seal (5)** in the **adjusting nut (12)**.
5. Grease the sealing groove and install the adjusting nut **o ring (11)** in the groove.
6. Apply a thin film of lubricant to the pocket and the recess in the **valve body (1)** and install the **plug seal (5)** with the metal back towards the recess facing away from the pressure.
- 7.
8. Check the **plug (6)** outside diameter for surface defects such as scratches, dings, nicks, or sharp edges that could affect the sealing area. [See 8.2 SANDING TIPS for repair.](#)
9. Support the **valve body (1)** so that the plug hex can pass through unobstructed.
10. Install the **plug (6)** (hex side down) in the **valve body (1)**.
11. Check the surface finish of the **inserts (7)** making sure they do not have any scratches, dings, nicks or sharp edges that could affect the sealing area. [See 8.2 SANDING TIPS for repair.](#)
12. Inspect the insert **o-rings (8)** for any possible non-conformity.

13. Install the insert **o-rings (8)** into the **insert (7)** grooves and coat with grease to retain the rings.
14. Make sure the entire sealing surface is thoroughly greased.
15. Apply a thin film of grease to the entire I.D. of the **insert set (7)**.
16. Place the **inserts (7)** around the **plug (6)** in the **valve body (1)** making sure it slides into the roll pins.
17. Apply thread compound (Never-Seez) to the **adjusting nut (12)** threads and **adjusting nut (12)** sealing surfaces.
18. Grease the **seal ring (10)** groove and insert the **o ring (9)**.
19. Place the **seal ring (10)** on the top of the **inserts (7)**.
20. Install the **adjusting nut (12)** into the **valve body (1)** and tighten until snug and back off  $\frac{1}{4}$  turn from the snug position.
21. Apply thread compound (Never Seez) grease to the **plug bolt (14)** threads and tighten it with the allen wrench on the **adjusting nut (12)** side of the **plug (6)**.
22. Apply thread compound (Never Seez) to the threads on the **SafeTap™ grease fitting (2)**. Install grease fittings and torque to 80 ft-lbs.  
NOTE: Do not use Teflon tape on the grease fitting.
23. Remove excess grease from valve bore.
24. Inspect plug alignment and adjust as necessary with **adjusting nut (12)**.
25. Apply Removable Threadlocker (blue) in the threads of the stud end and screw the **studs (3)** until tight. Screw the **nuts (4)** over the **studs (3)**  
Note: Do not use Red High Strength Threadlocker.



## 6.0 DISASSEMBLY PROCEDURE

Note: If **handle adapter (4)** or **adjusting nut (14)** appears to be stuck or locked, pressure may be trapped in the valve. This is also known as "pressure locking." Do not attempt to disassemble a "pressure locked" valve. See section [8.1 DISASSEMBLY TIPS](#) for pressure relieving procedures.

- Remove the **handle adapter (4)** and **stop collar (5)**. Turn valve over so that the **adjusting nut (14)** is facing up. Leaving the bottom **plug bolt (1)** in place, screw out (turning counter-clockwise) the **adjusting nut (14)**. This will allow the entire internal assembly (**adjusting nut (14)**, **plug (10)** and **inserts (12)**) to be removed from the valve pocket at once.
- Remove the **plug bolt (1)** that attaches the **plug (10)** to the **adjusting nut (14)**.
- Remove the **plug (10)** and **inserts (12)**.
- Remove the **insert o-rings (11)**, **adjusting nut o-ring (13)** and **plug seals (9)**.
- Clean all of the old lubricant and debris from the parts and valve body internal profile.

## 7.0 MAINTENANCE

Valves should be greased as part of a regular maintenance program. Regular greasing will increase the service life of the internal valve parts. Routine disassembly and cleaning as part of a maintenance program can prevent unnecessary damage to the valve body. Dixie Iron Works, Ltd. recommends that valves be greased after every job or every 5 actuations, whichever one comes first.

Valves should be greased according to the severity of use. Each operating company should establish guidelines for a greasing and/or disassembly program. These guidelines should be based on the operating conditions. Special consideration should be given for conditions in which the following would be involved:

- Abrasives in the fluid stream
- High flow rates
- Caustic or Acidic fluid streams
- High Temperature
- Fluid Streams that would act as solvents such as condensate
- High number of valve actuations

Valves should not be greased while under pressure unless a Greaseal™ plug is being used. In addition, valves should not be disassembled for repair while part of an operating arrangement such as a manifold. This should not be attempted even though the valve may be isolated from the fluid stream by other valves.

If the valve is NOT pressurized, MSI recommends greasing the valve to a minimum of 3,000 psi greasing pressure. If the valve is pressurized (and a Greaseal™ plug is being used), the greasing pressure needs to be greater than the internal pressure of the valve, but always less than the rated working pressure of the valve. The greasing pump must have pressure measuring capability.

Do **not attempt to disassemble a "pressure locked" valve.** See section [8.1 DISASSEMBLY TIPS](#) for pressure relieving procedures.

## 8.0 REPAIR AND INSPECTION

**When repairing a MSI plug valve, the following basic guidelines can help you ensure a good hydrostatic test of the reassembled valve.**

Disassemble the valve completely. See section [6.0 DISASSEMBLY PROCEDURES](#) for detailed instructions on valve disassembly. Remove old grease and debris from valve pocket with a solvent and inspect for wear or damage such as:

- In the adjusting nut seal bore of the pocket: Scratches could be caused by previous installation of a damaged adjusting nut. Dings can also occur during assembly. Pitting is usually caused by failure to disassemble and clean valves after they are in service. Use your fingers to feel for any surface defects which may either fail to seal against the o-ring or may even damage the o-ring during assembly.
- On the adjusting nut o-ring groove area: Check for scratches, dings, or pitting. Dings and scratches here are usually caused by careless use of sharp metal objects when trying to remove old o-rings. Feel for any raised edges that might scratch the internal seal bore of the valve body and sand or file as necessary.
- On the adjusting nut threads: Check for damaged threads, especially the lead thread. Use your fingers to check for any raised edges and carefully sand as needed. Severely damaged threads must be repaired at the factory.
- On the pocket walls: Scratches, dings, or pitting, especially in the area immediately surrounding the valve bore. Use your fingers to feel for any surface defects which may either fail to seal against the o-ring or may even damage the o-ring during assembly. Check for any sharp edges around the valve bore that can cut the insert o-rings. These can be caused by using a bar when swabbing excess grease or using a bar to carry the valve.
- On the internal threads: Check for damaged threads, especially the lead thread. Use your fingers to check for any raised edges and carefully sand as needed. Severely damaged threads must be repaired at the factory.
- On the plug seal area: Check for scratches, dings, or pitting. Dings and scratches here are usually caused by careless use of sharp metal objects when trying to remove old seals.
- On the plug outside diameter: Check plug for washout, which will render the part unusable. Hold part in a well illuminated area and inspect for slight scratches in plug. If scratches are visible, use a 600 grit sandpaper to remove them.

On the insert inside diameter: Check segments for washout, which will render the parts unusable. Hold parts up to a well illuminated area and inspect for slight scratches in outer and inner diameters of inserts. If scratches are visible, use a 600 grit sandpaper to remove them.



If the flow bore is washed and eroded larger than when the bore I.D. was new, the plug and segment set can only be used when the wear conforms to the guidelines detailed below. Since the bore will no longer be a perfect circle, you must measure the largest gap from one side of the bore to the other. If the bore tapers in either direction, measure the largest dimension. Compare the measurement to the following maximum acceptable dimensions:

- **1" Plugs and Inserts – 1.090" max**
- **2" Plugs and Inserts – 2.120" max**
- **3" Plugs and Inserts – 3.120" max**
- **4" Plugs and Inserts – 4.120" max**
- **5" Plugs and Inserts – 5.190" max**

Plug valves seal on the downstream side or the side opposite the pressure. The o-ring in the segment is pressured inward, trying to collapse the inside wall toward the bore. Dimensions larger than these guidelines will produce walls too thin to support the working pressure of the valve and these parts should be scrapped.

Because the bore is larger than when new and because the eroded area tends to be uneven, worn parts create a larger internal upset in the valve which increases turbulence. This increased turbulence means that the rate of wear will increase exponentially so special consideration should be given to the application of valves with worn parts to minimize the possibility of failure during the course of the job. Continued use of parts with eroded flow bores may reduce the life of the valve body. MSI recommends that valves with working but washed parts within these guidelines be used in locations of the rig-up that see less abrasive flow.

See the [\*\*Minimum Wall Thickness Datasheet\*\*](#) for wall thickness inspection procedures and allowable erosion values.

## 8.1 DISASSEMBLY TIPS

Note: If **handle adapter (4)** or **adjusting nut (14)** appears to be stuck or locked, pressure may be trapped in the valve. This is also known as "pressure locking." Do not attempt to disassemble a "pressure locked" valve.

- The SafeTap™ grease fitting allows for the safe relief of trapped pressure within a valve. Extreme caution must be followed when attempting to relieve a pressure locking situation. Slowly turn the grease fitting ¼ CCW turn to relieve the pressure. Actuate the valve to ensure all pressure has been relieved. After the removal of all trapped pressure, you may remove all components. See section [1.1 SAFETAP™ GREASE FITTING](#) for more details on the SafeTap™ grease fitting

## 8.2 SANDING TIPS

**When repairing a MSI plug valve, the following basic guidelines can help you ensure a successful hydrostatic test of the reassembled valve.**

Sanding is necessary to repair blemishes from the sealing surfaces of parts.

- Sanding of scratches, dings, and pitting should always be done with 600 grit sanding cloth that is well lubricated with water or solvent. When sanding sealing surfaces, it is VERY important to avoid sanding in one spot continuously; sand evenly across the entire sealing surface. Sand scratches by moving the sandpaper around the plug, not up and down, along the length of the plug. If scratches cannot be removed utilizing this technique, replace the parts. If raised edges or dings in non-sealing areas are too large to be sanded effectively, you may use a rotary flapper-type sanding wheel. It is very important that you do not remove any material other than the actual raised edge. Do not remove any of the base material or you may permanently damage the valve and render it unsafe for use.

## 8.3 ASSEMBLY TIPS

**When repairing a MSI plug valve, the following basic guidelines can help you ensure a good hydrostatic test of the reassembled valve.**

If you choose to mix old and new parts, you must make absolutely sure that the old part does not have any defects. Using 600 grit sanding cloth, wet sand any surface blemishes as described in section [8.2 Sanding Tips](#).

- See section [3.0 ASSEMBLY PROCEDURES](#) for detailed assembly instructions.



## 9.0 STORAGE

Disassemble the valve completely. See section [6.0 DISASSEMBLY PROCEDURES](#) for detailed instructions on valve disassembly. Remove old grease and debris from valve pocket with a solvent and inspect for wear or damage per [8.0 REPAIR AND INSPECTION](#).

- Drain after testing. All equipment should be drained and lubricated after testing and prior to storage.
- All components and assemblies should be cleaned of dirt, rust, and other contaminants.
- Rust Prevention: Equipment should have exposed metallic surfaces protected with a rust inhibitor which will not become fluid and run at a temperature less than 125°F (52°C).
- Sealing surface protection: Exposed sealing surfaces should be protected from mechanical damage.

## 9.1 SHELF LIFE

The following is recommended for maximum equipment shelf life:

# of Months in Storage	Manufacturers Recommendations
0-3 months	Nothing required
3-6 months	Re-grease and operate. Operate by rotating the plug. Check to see that rotation is smooth without grinding or scraping.
6+ months	Disassemble, rebuild & retest the valve. Replace all internal seals

## 10.0 ACCESSORIES

Use only MSI recommended accessories.

MSI Part Number	Description
VC0393	Valve Operating Bar

## 10.1 GREASES

Use only MSI recommended greases. Greases intended for gate valves or other applications may result in failure to achieve a good test and may actually damage the new parts.

MSI Part Number	Description	Manufacturer's Website
VC0012	#972 General Service (size K)	Val-Tex
VC0426	#972 General Service (size 5.5)	Val-Tex
VC0669	#972 General Service (size V)	Val-Tex
VC0527	#750 Low Temperature (size J)	Val-Tex
VC0402	#750 Low Temperature (size K)	Val-Tex
VC0357	#700 CO2 / Hi-Temp / Condensate (size J)	Val-Tex
GREASE002 *	1502-S-7 Low Pressure Testing (7 lb can)	Val-Tex

\*Val-Tex 1502 grease is for hand application only and not to be pumped. Therefore, it is to be used only during the assembly process. Inject body grease prior to testing and after each actuation.



## 10.2 GREASE REQUIREMENTS

Valve Size	Approximate amount of grease "K" size stick
1" VALVE	1/3 STICK
2" VALVE	1/2 STICK
3" VALVE	1 STICK
4" VALVE	3 STICKS
5" VALVE	5 STICKS

## 10.3 ACTUATORS

MSI uses the following brands of actuators. Information is available by clicking on the hyperlinks.

Pneumatic

[El-O-Matic](#)

Hydraulic

[Damcos](#)

Gear Operated

**Williams Machine**



## **10.4 RUBBER PRODUCTS**

MSI offers many O-ring and plug seal materials for a variety of environmental and operating conditions.